

MPG  SERIES™
Systems And Components

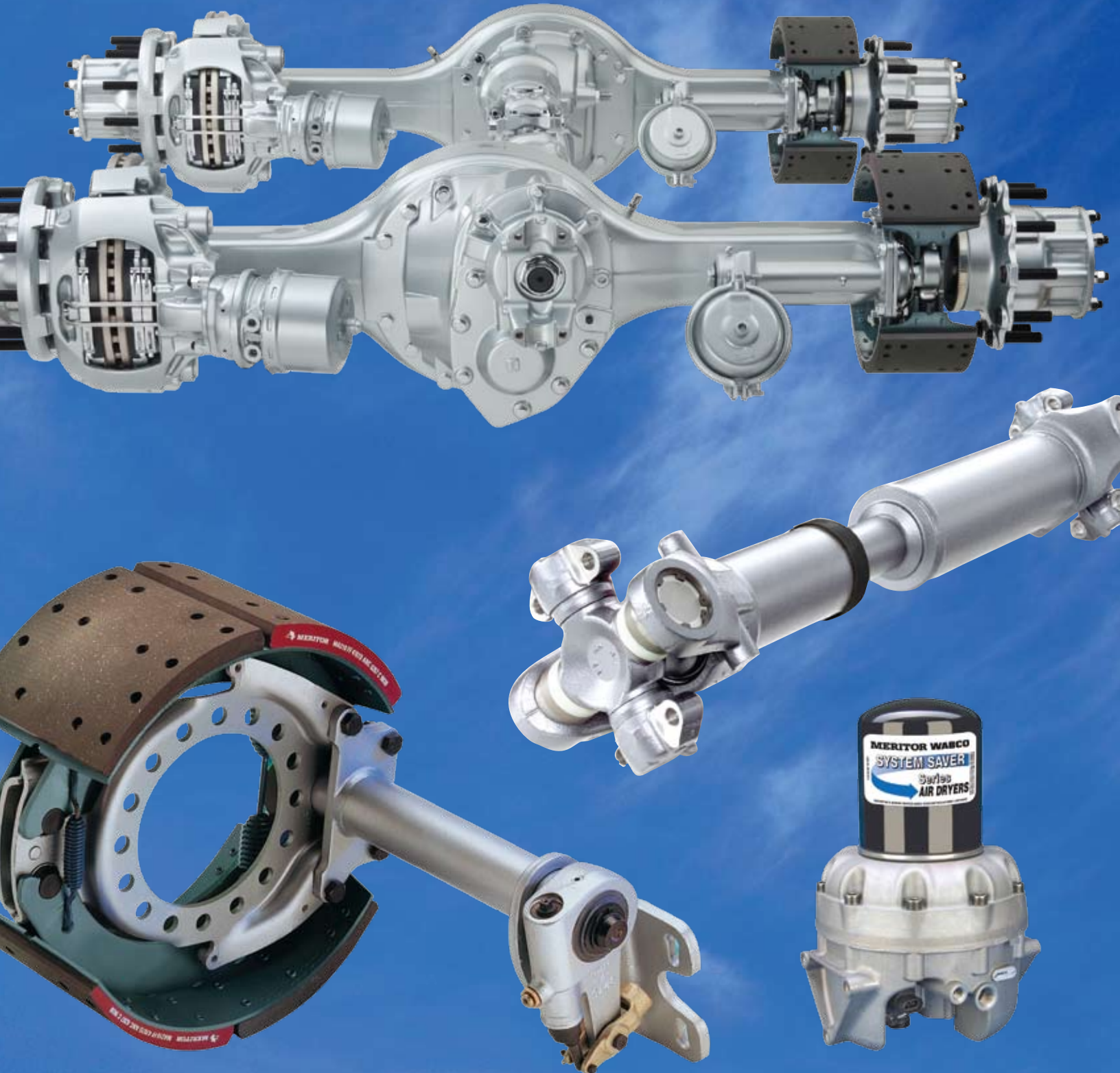

MERITOR®

An **ArvinMeritor**™ Brand



Efficiency to run your business.

Today, ever-increasing costs are putting intense pressure on already tight fleet operating margins. Equipment, labor and diesel fuel are all going up. The result is a financial burden that threatens the livelihood of every trucking business on the road today.

This is why we engineer efficient products that are designed to:

Drive more productivity!

MPG SERIES™ components are engineered to deliver superior operating efficiency with less downtime, to equip you with a productivity gain in today's workplace.

Maximize payload gains.

Stronger, yet lighter-weight MPG SERIES components enable your vehicles to haul more payload, so you can earn more profits per mile.

Score more miles per gallon.*

Fuel is your largest expense, and the MPG SERIES can help you cut that with components designed to optimize operation and lighten your truck.

Comprised of both current products and future technologies, the MPG SERIES reflects ArvinMeritor's position as a worldwide technology leader. We offer proven engineering designs and advanced solutions.

*The fuel savings described throughout are estimates only. Actual fuel savings may vary and will depend on a variety of factors beyond ArvinMeritor's control, including load, vehicle type, driver performance, distances traveled, vehicle speed, road conditions, etc.



The Meritor® 14X™ Tandem Drive Axle.

Raise Your Xpectations!

The next evolution of one of trucking's most successful axles is here! The Meritor 14X Tandem Drive Axle delivers every benefit of its predecessor, the legendary Meritor RT-40-145 – and more. Including a more robust, 20% larger Inter-Axle Differential (IAD) to handle today's higher-torque engines. It features as standard equipment the smooth, efficient performance of our premium Meritor Amboid™ design. It also provides the industry's fastest and most complete range of axle ratios – from 2.47 to 7.17. And it is the lightest-weight axle in its class.

- More robust Inter-Axle Differential (IAD)
 - 20% larger than the competition, with fewer parts
 - Ability to handle up to 2050 lb. ft. of torque in certain applications
 - New IAD needle bearings system for reduced heat and wear, which delivers increased reliability



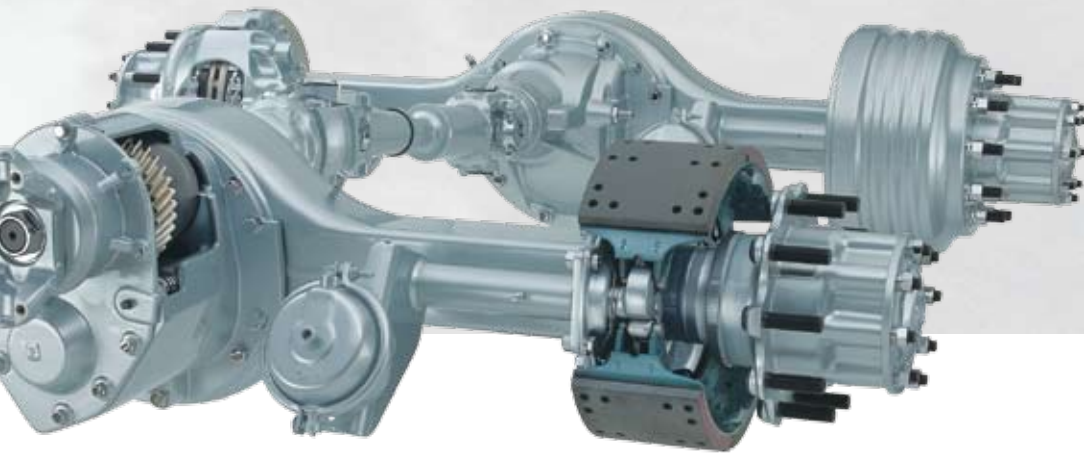

■ Premium Amboid design now standard

- Improved driveline angles reduce vibration while increasing ride quality and overall component life at no additional charge
- Amboid gearing on the rear drive axle allows parallel positioning between forward and rear drive axles

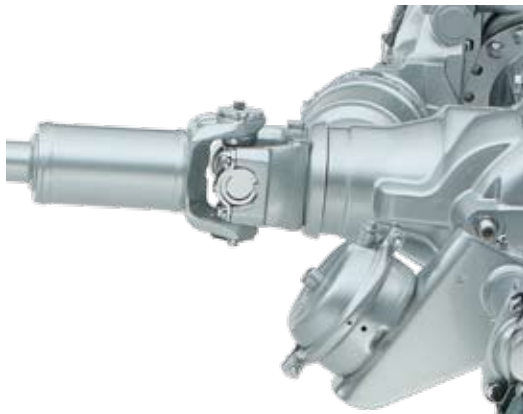

■ Most complete range of ratios in the industry

- New 2.47 ratio is the fastest axle ratio in the industry and the most efficient solution for vehicles with direct drive transmissions
- 2.47-7.17 is the widest range to match your application and specific engine manufacturer's recommendations
 - 2.47-4.11 Amboid pinion position
 - 2.64-7.17 Hypoid pinion position

Additional Features And Benefits:

- Optimizes the use of wide-based tires with optional DualTrac™ housing
 - Offers bearing life equal to dual-tire-configured tandem axles
 - Allows ability to convert between wide-based single tires and duals within legal axle spread dimensions
 - Offered in 9.5-mm and 11.0-mm housing wall thickness options



Courtesy of Bridgestone Bandag Tire Solutions

■ Industry-leading axle breather

- Designed for today's extended-drain synthetic lubes
- Helps prevent water and other contaminants from entering the axle while keeping lube in place





Meritor® Q Plus™ Cam Brake With Stamped Steel Spider And Meritor Automatic Slack Adjuster (ASA).

Saves weight and your brakes!

The industry-standard Meritor 16.5" Q Plus cam brake with 1.75" offset stamped brake spiders saves 6.5 pounds per brake while also saving 4 to 5 pounds per spider. The Q Plus combines with the Meritor Automatic Slack Adjuster to make the lightest cam brake package on the market.

- Increases service life and mileage between relines by providing more lining thickness
- Provides wider brake shoes with increased lining life – 23.2% more wearable lining volume on rear brakes; 37.5% more wearable lining volume on front brakes
- Now available with “brake-through” PlatinumShield™ coating technology that solves the industry’s rust-jacking problem
- Provides parts commonality among steer, drive and trailer brakes for reduced parts inventory and increased remanufactured product options
- The unique Automatic Slack Adjuster design keeps the brake in constant adjustment, eliminating the need for frequent under-the-truck brake adjustments, lowering brake maintenance costs, reducing vehicle safety inspection citations and allowing for optimum brake performance
- Specify SteelLite X30™ brake drums for additional weight savings

Meritor SteelLite X30™ Hubs And Drums.

Significant weight savings!

Lightweight, yet strong, SteelLite X30 hubs and drums reduce vehicle weight by up to 200 pounds for a typical tandem-axle tractor/trailer or medium-duty combination.

- Reduces maintenance with a durable one-piece design that provides long operating life
- Delivers on average a 20-pound weight savings vs. a cast drum on a 16.5" x 7" wheel
- Specify stamped steel spider Q Plus cam brake and Meritor ASA for a lightweight package
- Offers OEM or retrofit availability plus interchangeability with cast drums for easy upgrade





System Saver 1200 Plus Air Dryer.

Reduces weight. Increases performance!

The System Saver 1200 Plus Air Dryer delivers increased brake system protection from contamination while its reduced weight allows greater payloads.

- Reduces weight (at 19.8 pounds, it is the lightest integrated purge air dryer on the market)
- Replaceable spin-on cartridge takes less than five minutes to change
- Provides parts compatibility with previous models for easy replacement of purge valve and turbo cutoff valve
- Extends the life of other air brake system components via coalescing filter

Air Disc Brakes For Tractors And Trailers.

Longer life!

Proven twin-piston and single-piston air disc brake designs for tractors enhance operational efficiency. Our family of single-piston air disc brakes for trailers delivers low cost of ownership.

- Lighter weight* – facilitates increased payload and fuel savings
- Optimized stopping power – provides the shortest stopping distance
- Ease of maintenance – significantly reduces downtime during lining changes
- Higher efficiency – provides more responsive braking
- Optimized stability – provides more consistency in side-to-side torque output

*Based on weight comparison to a tractor equipped with 16.5" x 5" front brakes and 16.5" x 8 5/8" rear brakes.



Meritor Permalube™ RPL Driveline.

Eliminates maintenance!

Our proven Permalube RPL drivelines are built and warranted for longevity. Permanently lubricated to reduce operating and maintenance costs, Permalube drivelines deliver longer U-joint life on today's gear-fast/run-slow drivetrains.

- Provides the longest U-joint life – proven to last over one million miles
- Only driveline available that is permanently lubricated and sealed for life
- Reduces drivetrain vibration through exact balancing to tighter specifications
- Driveline removal simply requires removing four bolts
- Integral U-joint bearing cups are permanently assembled/retained with steel straps
- 4-Year/400,000-Mile warranty vs. competitors' warranty at 3 Years/350,000 Miles

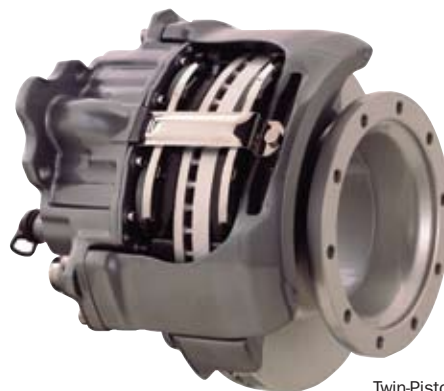

Twin-Piston Air Disc Brake



Meritor WABCO OnGuard™ Collision Safety System.

Also guards against unnecessary fuel consumption!

OnGuard features Adaptive Cruise Control (ACC), which helps keep drivers in cruise longer, avoiding unnecessary shifting and hard accelerations, which translates to less fuel consumption. And as the first collision safety system with Active Braking, OnGuard uses forward-looking radar to monitor potential collisions ahead and help drivers to avoid or greatly reduce the impact of a collision.

- OnGuard eliminates speed changes and unnecessary fuel consumption while also maintaining a safe following distance
- As a result, the driver can spend more time in top gear, which saves fuel
- OnGuard is always on – even when you're not in cruise control

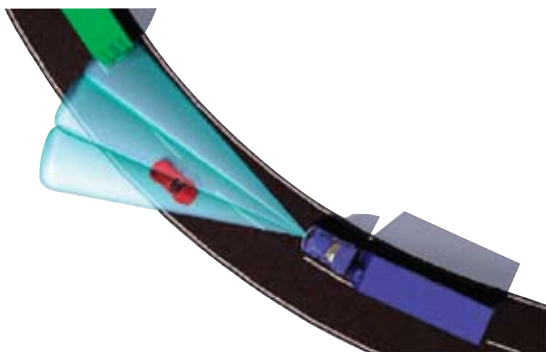

RideSentry™ MPA 38/40 Series Trailer Suspensions With PinLoc™

Increases operating efficiency while dramatically reducing maintenance!

The RideSentry MPA 38/40 Series trailer suspension, with its unique PinLoc System, makes it easy for drivers to secure the slider and get the vehicle moving. Which saves time, reduces downtime and maintenance costs and helps to ensure prompt delivery.

With its integrated slider, trailer axles and brakes, RideSentry provides a lightweight, efficient package that also provides the most durable and stable ride on the market.

- PinLoc combines automatic angled locking pins, parking brake interlock and Air Assist to help protect against slider and trailer damage
- Combines competitive weight with impressive structural durability, including a high-strength steel frame
- Delivers increased fuel economy and longer tire life, with its 100% air ride and unique bushing design
- Facilitates highly accurate alignment for efficient operation and superior vehicle control while minimizing tire wear
- Improves vehicle control with a smooth and stable ride



Meritor® Tire Inflation System by P.S.I. With ThermALERT™ Option.

Continuous protection! Continuous savings!

The Meritor Tire Inflation System by P.S.I. with ThermALERT option is the market's leading continuous tire inflation system for trailers. It offers increased fuel economy, safety and longer tire life, plus optional wheel-end heat sensor warning technology.

- Provides annual cost savings of up to \$1,200* per trailer in fuel, tread wear and maintenance
- Prevents catastrophic failure and associated costs from running underinflated
- Continuously optimizes tire pressure to maximize payload

*The average annual savings per trailer with MTIS includes \$500 in fuel, \$200 in tread wear, \$150 in maintenance and \$350 in tire downtime – for an annual savings of up to \$1,200!

Future MPG SERIES Technology.

At ArvinMeritor, we're celebrating over "100 Years of Forward Thinking" with a passion for introducing "next generation" drivetrain product solutions that deliver real customer advantages through advanced design and state-of-the-art manufacturing technology.

As we continue to unveil new waves of MPG SERIES innovations, you can count on unsurpassed product performance, engineering expertise and committed customer service to continue to define ArvinMeritor's role as a world leader in commercial vehicle innovation.

Moving You Forward. Behind You All The Way.

It takes strong heritage and an equally bold vision to innovate components and systems that revolutionize fleet efficiency. ArvinMeritor is the one global leader that offers it all – right now. No other manufacturer even comes close to providing the complete efficiency package that our Meritor MPG SERIES represents. Especially when you consider the unsurpassed aftermarket support, the industry's most knowledgeable, committed reps, dedicated customer service and technical support, complete online catalogs, expert training programs, and comprehensive product warranty support. ArvinMeritor delivers the advantages you need for today. And tomorrow.

By providing so many efficiencies, the benefits of the Meritor MPG SERIES add up quickly.



Want Next- Generation Fleet Efficiency? Let's Talk.

For more information about how our next-generation MPG SERIES can significantly increase your operating efficiency, see your truck or trailer dealer today or go to mpgseries.com.



ArvinMeritor[™]

Meritor Heavy Vehicle Systems, LLC
2135 West Maple Road
Troy, Michigan 48084 USA
800-535-5560
arvinmeritor.com

Litho in USA
Issued 3-10
SP-1083 (13028/11900)
©2010 ArvinMeritor, Inc.