

# MERITOR®

## MERITOR XTENDED LUBE – MXL™ DRIVELINES

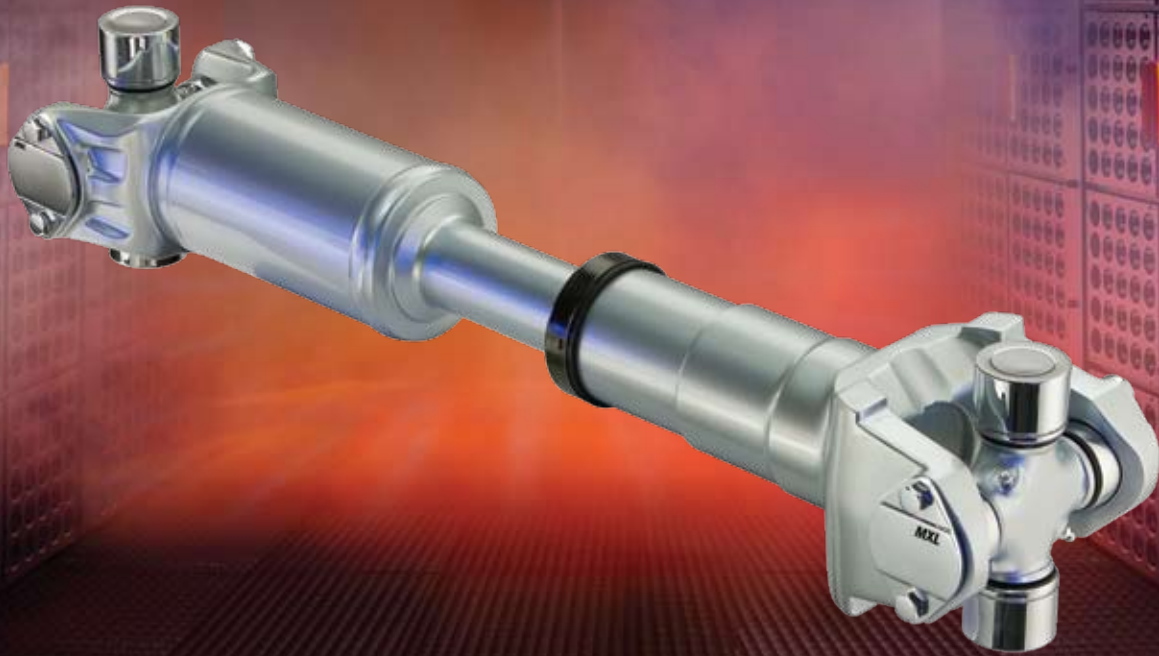

### Performance Advantages:

- The new "standard" for fleets that prefer longer life, extended maintenance intervals and low life cycle costs
- Lubrication intervals for both U-joints and slip section extended to **100,000 miles** for linehaul applications
- Based upon proven U-joint expertise, blending both the RPL and RN technologies

## MERITOR XTENDED LUBE – MXL™ DRIVELINES

100,000-Mile Lube Intervals\*

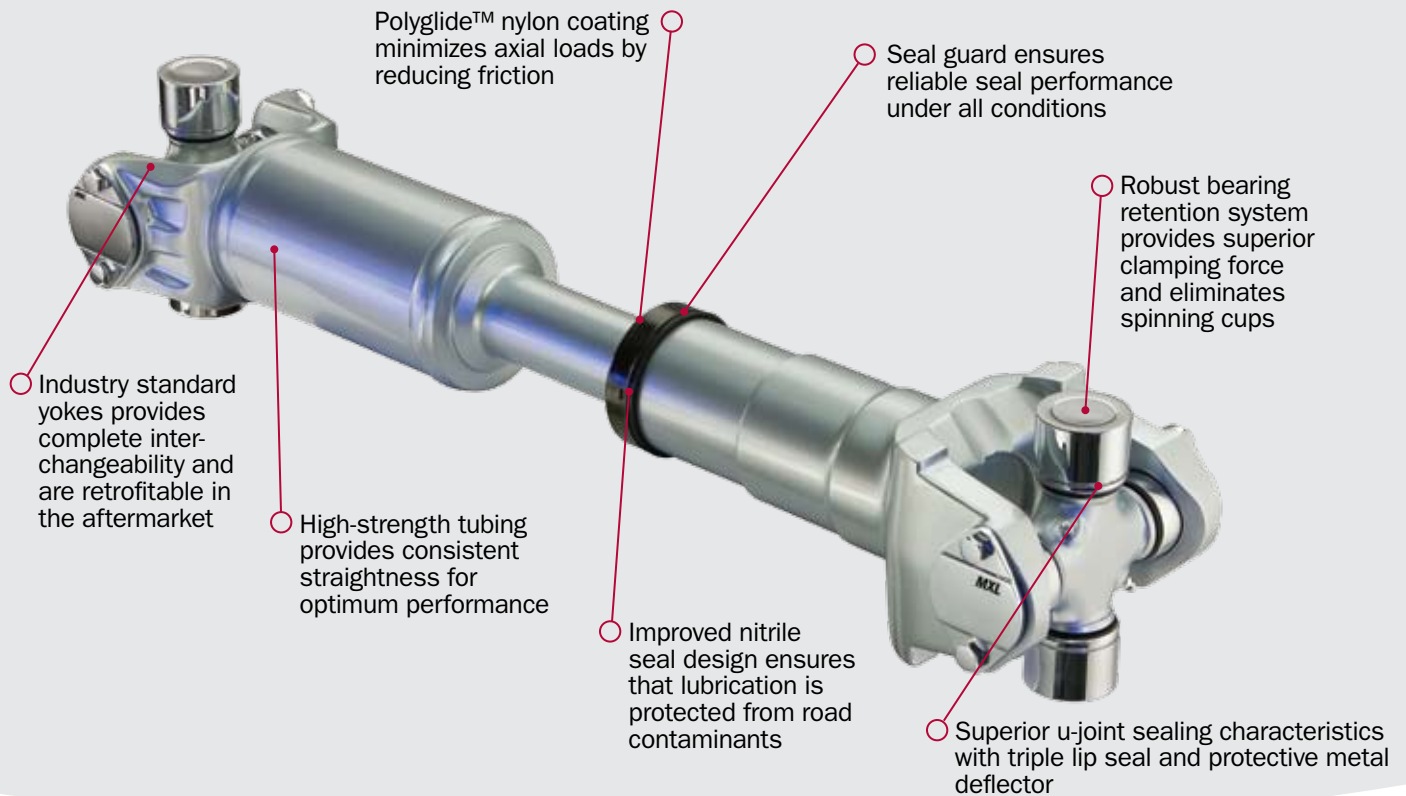

Available in popular sizes: 17N, 176N and 18N in both easy service and full round styles.

**Moving you past your competition is the mobility that ArvinMeritor gives you.** And, what better example of this mobility can be seen than in Meritor® universal joints and driveline components?

These components have been linking transmissions and drive axles for trouble-free driving for decades. Now Meritor has combined technologies to create the Meritor XTended Lube - MXL™ Driveline.

\*Inspection intervals may differ. See ArvinMeritor driveline manual for details.

# Features and Benefits:

## ○ Extended Lubrication Intervals

- Lube intervals of 100,000 miles for both slip section and u-joint reduce operating and maintenance costs

## ○ Advanced Sealing - Slip Section

- Field proven internally mounted advanced nitrile seal design ensures lubrication is protected from contaminants and prevents water intrusion



- Seal shroud incorporated from RPL design improves sealing characteristics and retains seals securely in place

## ○ Maximum Life - U-Joints

- Incorporates and builds upon the proven RN series U-joint design with RPL premium sealing technology
- U-joints are equipped with triple-lip seals to keep lubrication in and contaminants out for longer life
- U-joints feature proven technology including nylon thrust washers that eliminate metal-to-metal contact, preventing wear and extending life
- 3 year, 350,000 mile linehaul warranty
- 100,000 mile lubrication intervals for linehaul applications



## ○ Center Bearing - Self Aligning

- Standard on MXL
- Accommodates +/- 5 degree driveline angularity
- Sealed bearing with integral deflector shield and grease barrier protects the bearing against contamination without the use of external deflectors



## ○ Additional Performance Advantages

- Available in both full round and easy service yoke configurations
- Corrosion resistant seal guard protects and secures advanced slip seal improving durability over "booted" designs
- Standard with Polyglide™ coating which minimizes axial loads by reducing friction
- Robust easy service u-joint retention system eliminates spinning cups, through improved clamping force
- Tighter balance specifications reduces the potential for vibrations and ensures smooth operating performance



**ArvinMeritor™**

Meritor Heavy Vehicle Systems, LLC  
2135 West Maple Road  
Troy, Michigan 48084 USA  
800-535-5560  
[www.arvinmeritor.com](http://www.arvinmeritor.com)

Litho in USA  
Issued 03-09  
SP-0976 (47865/11900)  
©2009 Meritor, Inc.